

SERVO-TOP

QE5542

CE

Type

ST40SE

Instruction Manual

Part 3

QUICK-ROTAN Elektromotoren GmbH
Königstraße 154
67655 Kaiserslautern
Tel: 0631 / 200 38 80
Fax: 0631 / 200 38 62
E-Mail: tech.suppl@quick-rotan.com
www.quick-rotan.com

English 2002-03-13

Contents

Page

Part 3

11.	Survey and List of Parameters	11.1 - 11.11
11.1	Explanation of Parameter Survey	
11.2	Explanation of Parameter List	
11.3	Parameter Survey	
11.4	List of Parameters	
12.	Electrical Connections Diagram	12.1 - 12.7
13.	Maintenance and Repair	13.1

Technical updatings reserved!

11. Survey and List of Parameters

11.1 Explanation of Parameter Survey

The parameter survey is designed as an aid for finding parameters quickly. It is a summary of references for the parameter list. Listed behind each reference are all parameters which exert an influence on the function described by the reference.

The parameter survey is divided into five columns:

Column 1 shows the references (functions) to which parameters are assigned.

Column 2 shows the abbreviations of the respective functions.

Column 3 shows all parameters (setting numbers) belonging to the respective reference.

Column 4 shows, for each function (reference) which controls inputs or outputs, the applicable indications such as Ex or Ax which can also be found on the connections diagram.

Column 5 shows, for each function (control inputs (Ex) or control outputs (Ax)), the respective plugs with the number of contacts (see connections diagram).

Example for searching a parameter:

Keyword (function): inverse rotation

The parameter survey shows in column 3 the parameter numbers 618, 623, 801.

Suppose that the inverse rotation function is to be enabled. The parameter list shows this function under parameter number 618.

11.2 Explanation of Parameter List

The parameter list is divided into 5 columns. These comprise, in

column 1: the parameter number,

column 2: is the explanation (meaning) of the parameters and the coding system of row 1 of the keys of the mini operator's panel, used when the parameter concerned can be programmed with the mini operator's panel,

column 3: the programming level (A, B, C) on which the parameter in question can be accessed,

column 4: the range of values within which the parameter in question can be set,

column 5: the value of the parameter in question is set on delivery ex factory.

Parameters having "either/or" validity (software switches) can merely be set to value I or II. In the case of such parameters, column 4 is empty.

Parameter numbers in acute brackets; e.g. <105>, mean the value (content) set for the parameter in question.

Example:

107 Speed for front backtack when <106> = I

I limited by <105>

II limited by <607>

Explanation:

Parameter 107 is valid only the the value (content) of parameter <106> = I.

If parameter 107 is set to I (<107> = I), then the speed for the front backtack is limited by parameter 105, e.g. <105> = 1500. If parameter 107 is set to II (<107> = II), then the speed for the front backtack is limited by the value of parameter 607, e.g. <607> = 4000.

11.3 Parameter survey ST40SE (2Z_846_0.HEX)

Function	Abbrev'n	Parameter	Input Output	Connection Socket/Contacts
Accelerate	DRZAN	722		
Brake	DRZAB	723/758/851		
Chopper	MESSER	714		
Control	REG	758/884/885 886/887/889 890/891/894 990		
Defect search	HWT	797		
Delay	VERZ	194/581/717 730		
Direction of rotation	DRR	800		
Feed reverse	TUM	721		
Hardware test	HWT	797		
Needle position	NAPO	700/701/702 703		
Operator panel	BDF	681		
Presser foot	PF	719/729/730		
Program	PR	206/221/851		
Programming level C	EBC	798		
Residual brake	STBR	718		
Seam end	NE	206		
Speed	DRZ	221/605/606 607/608/609 676/850		
Speed decrease	DRZAB	723/758/851		
Speed increase	DRZAN	722		
Speed limitation	DB	221/676		
Start delay	STVERZ	729		
Starting block	ANLSP	452/665		
Stop	STOP	206/452/665		
Thread clamp	FK	581/582		
Thread puller	FZ	581/582		

Thread trimming	SN	609/714/717
Time needed to switch on	EINZ	582/714/889
Timing output	TA	719/721

11.4 List of Parameters ST40SE (2Z_846_0.HEX)



No.	Function (Meaning)	Level	Range Values	of Value	Standard
194	(VERZ) Delay t6	B,C	0 - 2550	80	Kl. 1
206	(NE/PR/STOP) Interrupt/discontinue seam sections at speed = constant (<203> = II) I with treadle -2 II with treadle 0	B,C		II	Kl. 1
221	(PR/DB/DRZ) Speed limitation for sewing programs (or sewing program 1)	B,C	300 - 1500	1200	Kl. 1
452	(ANLSP/STOP) Input „run locking“ I yes II no (without function)	B,C		II	Kl. 1
581	(FK/FZ/VERZ) Delay in start-up time (ms) for thread clamp or thread puller	B,C	10 - 2550	80	Kl. 1
582	(EINZ/FK/FZ) Duration (ms) of thread clamp or thread puller	B,C	0 - 2550	200	Kl. 1
605	(DRZ) Actual speed in display I yes II no	B,C		II	Kl. 1
606	(DRZ) Speed: level 1 (min.)	B,C	30 - 640	180	Kl. 1
607	(DRZ) Speed: level 12 (max.)	B,C	100 - 1500	1200	Kl. 1
608	(DRZ) Speed level curve (treadle characteristic) I linear II not linear	B,C		I	Kl. 1
609	(SN/DRZ) Trimming speed 1	B,C	30 - 300	180	Kl. 1
665	(ANLSP/STOP) Run locking/stop I contact closed II contact open	C		I	Kl. 1
676	(DRZ/DB) Speed adjustment via potentiometer possible I yes II no	B,C		II	Kl. 1
681	(BDF) Operator panel push-button locked I yes II no	B,C		II	Kl. 1
700	(NAPO) Needle position 0 (reference position of the needle)	B,C	0 - 239	0	Kl. 1
701	(NAPO) Angular adjustment I with handwheel (teach-in) II by keys (+/-)	B,C		I	Kl. 1
702	(NAPO) Needle position 1 (needle down) (00010111)	B,C	0 - 239	75	Kl. 1
703	(NAPO) Needle position 2 (thread take-up lever up)	B,C	0 - 239	213	Kl. 1
714	(EINZ/SN/MESSER) Duration (ms) for chainstitch trimming or chopper	B,C	0 - 2550	100	Kl. 1
717	(SN/VERZ) Delay in start-up time (ms) for trimming method when the machine is not activated by the treadle	B,C	0 - 2550	100	Kl. 1
718	(STBR) Timing of residual brake (0 = brake off)	C	0 - 100	0	Kl. 1
719	(PF/TA) Timing output A4 (0 = 100% switching on)	B,C	0 - 100	40	Kl. 1
721	(TUM/TA) Timing output A5 (0 = 100% switching on)	B,C	0 - 100	40	Kl. 1
722	(DRZAN) Acceleration ramp 1 gradual 50 steep	B,C	1 - 50	45	Kl. 1
723	(DRZAB) Brake ramp 1 gradual 50 steep	B,C	1 - 50	25	Kl. 1

729	(STVERZ/PF) Start delay after lowering presser foot	B,C	0 - 2550	120	Kl. 1
730	(PF/VERZ) Lift delay for presser foot after seam end	B,C	0 - 2550	50	Kl. 1
758	(REG/DRZAB) Deceleration ramp	B,C		II	Kl. 1
	I braking as per <723>				
	II braking with maximal moment				
797	(HWT) Hardware test	B,C		II	Kl. 1
	I yes				
	II no				
798	(EBC) Programming level C	B,C		II	Kl. 1
	I yes				
	II no				
800	(DRR) Direction of motor rotation viewed from belt pulley	B,C		II	Kl. 1
	I left-hand rotation				
	II right-hand rotation				
850	(DRZ) Maximum motor speed	C		4500	Kl. 1
851	(PR/DRZAB) Brake ramp for stitch-count seams	B,C		I	Kl. 1
	I steep				
	II gradual				
884	(REG) Proportional amplification of the speed control (in general)	B,C	4 - 255	12	Kl. 1
885	(REG) Integral amplification of the speed control	C	0 - 100	30	Kl. 1
886	(REG) Proportional amplification of the order controllers	C	1 - 255	20	Kl. 1
887	(REG) Differential amplification of the order controllers	C	1 - 100	30	Kl. 1
889	(EINZ/REG) Time required for order controlling (0 = always)	B,C	0 - 2550	400	Kl. 1
890	(REG) Proportional amplification of the superior order controllers for the residual brake	C	1 - 50	25	Kl. 1
891	(REG) Proportional amplification of the lower speed controllers for the residual brake	C	1 - 50	20	Kl. 1
894	(REG) Rotational direction of motor and synchronizer	C		I	Kl. 1
	I different				
	II same				
990	(REG) Distance to position at switch over from speed control to position control	B,C	1 - 64	16	Kl. 1

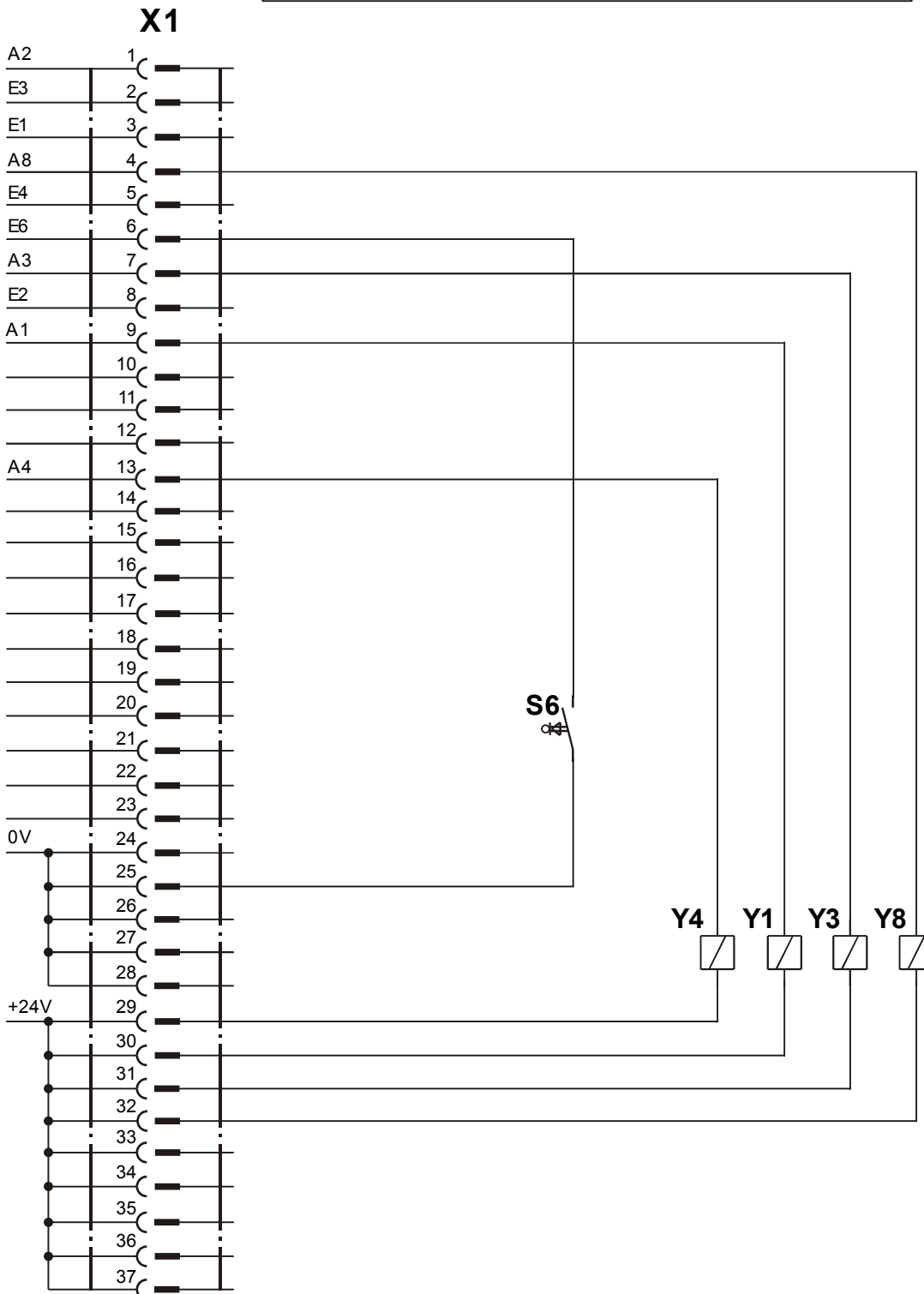
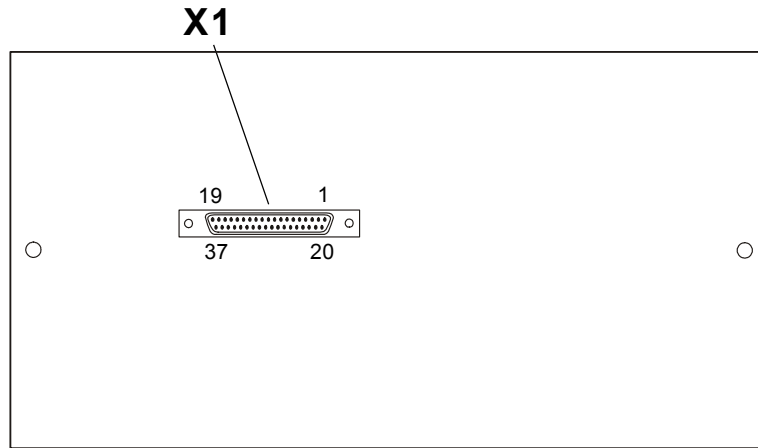
12. Electrical Connections Diagram ST40SE

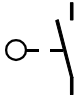
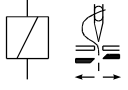
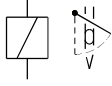

Bedeutung der Magnete bzw. Magnetventile, Taster / Meaning of magnets and/or solenoids and keys
 Signification des aimants resp. solenoides et touches / Significação dos imãs e/ou as solenoidas e teclas
 Significato dei magneti, delle valvole magnetiche e dei tasti / Significación de los imanes y/o los solenoides
 y pulsadores / Betekenis van de magneten resp. magneetkleppen, toetsen

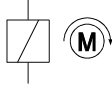
S6 	Anlaufsperr / Safety switch no run / Verrouillage de remise en marche / Bloqueio de arranque / Blocco avviamento / Bloqueo de repuesta en marcha / Startblokkering
Y1 I max 8 A * 	Fadenschneider / thread trimmer / coupe-fil / corte de linhas / rasafilo / cortahilos / draadsnijder
Y3 I max 8 A * 	Fadenzieher / thread puller / tire-fil / tirar de linhas / tirafilo / tirahilos / draadtrekker
Y4 I max 8 A * 	Taucherlüftung /
Y8 I max 8 A * 	Motor läuft / motor runs / moteur en marche / motor em movimento / motore in moto / motor en marcha / loop van de machine

- * Die Summe der Lastströme aller gleichzeitig eingeschalteten Stellglieder (Magnete, Magnetventile) darf den Wert von 4A nicht überschreiten (siehe hierzu Kapitel 2. Technische Daten).
- * The total of load currents of all servos activated simultaneously (solenoids, solenoid valves) is not allowed to exceed 4 amps (see also section 2. Technical Specifications).
- * Le total des courants de charge de tous les vérins (aimants, électro-vannes) activés simultanément ne doit pas dépasser 4 A (voir aussi le chapitre 2. "caractéristiques techniques").
- * A soma das correntes sob carga de todos os actuadores ligados ao mesmo tempo (ímans, solenóides) não pode ultrapassar o valor de 4A (ver também capítulo 2. Dados Técnicos).
- * La somma delle correnti di carico di tutti gli attuatori inseriti contemporaneamente (magneti, elettrovalvole) non deve essere superiore a 4 A (vedere il capitolo 2. Dati Tecnici).
- * La suma de las corrientes bajo carga de todos los elementos de todos los componentes de regulación conectados simultáneamente (imanes, válvula magnética) no podrá sobrepasar el valor de 4A (véase también el capítulo 2. de datos técnicos).
- * De belastingsstroom van alle tegelijkertijd ingeschakelde bedieningsschakels (magneten, magneetventielen) mag in totaal niet meer dan 4 A bedragen (zie hiervoor hoofdstuk 2. Technische gegevens).

13. Maintenance and Repair



!! Before starting maintenance or repair work, switch off the SERVO-TOP, separate the drive system from mains power (for instance by pulling out the mains plug) and wait for the motor to come to a complete stop.

General maintenance work must only be done by specially trained personnel paying close attention to the operating instructions.

The SERVO-TOP ist largely maintenance-free.

However, make sure to perform the following maintenance work:

Depending on the operating conditions, clean the drive system regularly, at least once a week, from any dust or lint. Make sure in particular that the ventilation louvres and cooling fins of the motor, especially the cooling fins between the motor and the control box, are perfectly clean (Fig. 13).

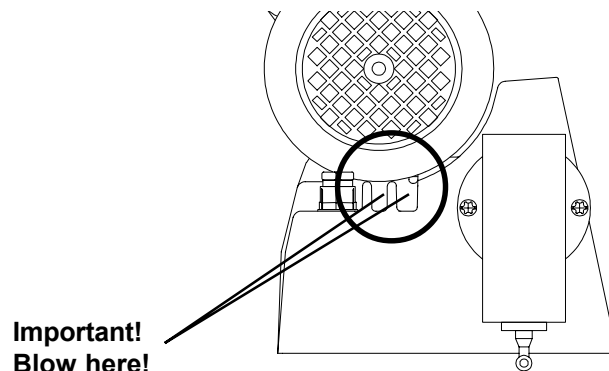

Fig. 13

Remove any threads caught on the synchronizer shaft or on the belt pulley and/or motor shaft.

Check if the drive system is perfectly secured to the stand and that the accessories (synchronizer on machine shaft, speed control unit on control box) are safely mounted in their respective positions.

Check the drive belt for any wear and for correct tension. Incorrect belt tension can increase noise and vibrations.



When opening covers or removing parts, apart from those removable by hand, live elements can be exposed. Connections can also be electrically live.

If you require to open the drive system before starting maintenance or repair work or before replacing any parts, disconnect the drive system from any and all power sources.

If maintenance or repair work on the open unit is unavoidable, this may only be done by qualified personnel familiar with the risks involved. Observe all regulations as per EN 50110.

There can still be capacitors carrying a charge in the power electronics system, even when the drive system has been disconnected from all power sources. To avoid injury by electrical shock, it is therefore essential to wait at least 10 minutes between mains power shutoff and opening the control box.

In order to protect semi-conductor components from overvoltage, use only high-resistivity measuring equipment when making checks on the control system.

Any repair or servicing work requiring skilled knowhow may only be done by qualified personnel authorized by Quick-Rotan.

We emphasize that in accordance with the product liability law we are under no responsibility for damages caused by our products if these are due to

- unqualified repair
- the use of components not authorized by us
- actions made by any persons not authorized by us.